

ADEKA ULTRA SEAL MC-2010MN OCM, Inc.

Sales Information: (847) 955-9700
 Technical Information: (800) 999-3959
 Contact Local Representative:



NSF NSF Certified for potable water

GENERAL DESCRIPTION

MC-2010MN is a chemically modified natural rubber product. This patented process chemically bonds a hydrophilic agent to the rubber. This permits the seal to undergo controlled expansion when exposed to moisture. This expansion capability provides a "double locking" water-stop. One from rubber's natural resilience and one from expansion.

Expansion occurs in three dimensions: width, height, and length. MC-2010MN has a unique stainless steel wire mesh embedded within the material. The wire mesh eliminates unnecessary expansion in the length and width dimensions. When fastened to concrete, the wire mesh prevents "winding" action and directs the expansion.

MC-2010MN has excellent durability and resistance to chemical contaminants. It can perform in a wide range of solutions such as sea water or cement water. The material does not contain any toxic substance or heavy metals and is environmentally safe. **MC-2010MN IS NSF 61 CERTIFIED.**

BASIC USE

Used in general below grade concrete joint work where water intrusion must be prevented. MC-2010MN is designed to replace conventional waterstop. It is also used for piping penetrations where pipe diameter exceeds 24".

NOTE: MC-2010MN must be placed between two rows of rebar. The required concrete coverage varies from 4.0" ~ 5.0" depending on concrete strength. For example, if concrete psi is 4260 or greater the required concrete coverage is 4.0". If the concrete psi is 2550 or less, the required coverage is 5.0". For complete coverage information see MC Coverage Data Sheet or call 800.999.3959.

MINIMUM WALL HEIGHT IS 6.5 FEET

PRODUCT DESCRIPTION:

SIZE: 20mm X 10mm - 0.78" X 0.39"

PACKAGING INFORMATION: 82 feet/case: 17.4 lbs/case

Hardness A30 (JIS K 6253) (ASTM D2240)

Tensile Strength (MPa) 0.9 (JIS K 6251) (ASTM D412)

Elongation (%) 560 % (JIS K 6251) (ASTM D412)

Volume % Change : 120 % (In House)

Vulcanization No

Specific Gravity 1.18 (JIS K 6350) (ASTM D792)

(Tested by press sheet of MC compound)

*** Property measurements are representative and are not considered as standard values.**

INSTALLATION

ALL METHODS OF INSTALLATION REQUIRE A MINIMUM OF 4.0" ~ 5.0" COVERAGE SEE NOTE

METHOD 1: (Attaching waterstop to smooth concrete)

1. Surface of the concrete must be clean, dry and free from any loose debris.
2. Paint both concrete and MC-2010MN with appropriate adhesive (3M-2141, Bostik 1142, Scotch Grip 1357 or equal). Allow adhesive to become tacky (approximately 15 minutes) - firmly press MC-2010MN onto adhesive. Place a nail or screw every 10" ~ 12" (approximately).
3. Place concrete without displacing or disturbing the position of the waterstop.

METHOD 2: (Attaching waterstop to rough concrete)

1. Surface of the concrete must be clean and free from any loose debris or standing water.
2. Apply small bead of Adeka Ultra Seal P-201. Use enough P-201 to fill any void between MC-2010MN and the concrete surface)
3. Firmly press MC-2010MN into the P-201 while it is still in the paste state. Place a nail or screw every 10" ~ 12" (approximately).
4. Use a wet tool or gloved finger to remove any excess P-201.
3. Place concrete without displacing or disturbing the position of the waterstop.

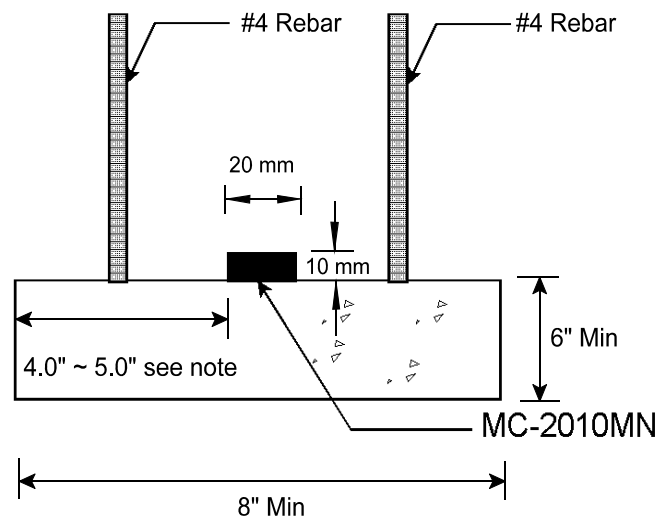

ADEKA ULTRA SEAL MC-2010MN

General Installation Procedures

Waterstop wall/slab joint

Place a small bead of Adeka Ultra Seal P-201 on any rough or scarred area prior to attaching MC-2010MN.

Attach MC-2010MN to the concrete by one of the following methods:

1. Attach with nails or concrete screws placed every 10" ~ 12" (approximately). If the concrete is rough, apply P-201 prior to attaching MC-2010MN.

Smooth, clean and dry concrete:

2. Use a fast setting rubber adhesive
Example - 3M-2141, Bostik 1142M to fasten MC-2010MN to concrete. Follow adhesive manufacturers recommendation.

3. Use Adeka Ultra Seal P-201 on rough concrete. P-201 can be used on vertical or overhead rough concrete when fastened with screws or nails.

Site conditions may warrant the use of a combination of attachment methods. Use P-201 on all corner joints and parallel splices.

Keep MC-2010MN taut and flat against the concrete during the attaching process. Do not allow any gap between the concrete and the MC-2010MN.

*** NOTE:** MC-2010MN must be placed between two rows of rebar. The required concrete coverage varies from 4" ~ 5" depending on concrete strength.

For complete coverage information see reverse side or see MC Coverage Chart at www.adeka.com

